



Temperature-Controlled MOSFET Protection Circuit

S. Jey Branav Rajan¹, M.K. Sangeetha², M. JoiceMalini³, G. Rajeswari⁴

¹Department of Instrumentation Engineering, Madras Institute of Technology, Anna University, Chennai

²Department of Science and Humanities, A.V.C. College of Engineering, Mannampandal

³Department of Science and Humanities, A.V.C. College of Engineering, Mannampandal

⁴Department of Science and Humanities, A.V.C. College of Engineering, Mannampandal

¹Corresponding Author E-mail: worldtechno222@gmail.com

ABSTRACT: Thermal stress is one of the most common reasons for failure in power electronic circuits, battery protection circuits, and motor driver circuits. Prolonged overheating can result in decreased efficiency, damaged components, or a complete circuit breakdown. This paper describes the design and simulation of a simple and low-cost temperature-protection circuit for a MOSFET using an NTC thermistor and an LM358 operational amplifier as a comparator. The thermistor circuit continuously tracks temperature changes, and a potentiometer is used to set the temperature threshold. If the temperature measured exceeds the set threshold, the comparator output activates a control circuit driven by a transistor to switch off the load via an IRFZ44N power MOSFET. The normal and faulty conditions are indicated by LEDs and a buzzer. The simulation of the proposed system using Proteus software has confirmed the functionality and response characteristics of the circuit. The simulation results show that the circuit provides effective thermal protection with a fast response and a simple circuit design, making it suitable for use in power modules, battery protection circuits, motor drivers, and solar charge controllers.

Keywords: Temperature protection, LM358 comparator, NTC thermistor, MOSFET switching, Thermal safety

1. Introduction

Thermal management is an essential requirement in modern electronic systems, especially in power electronics, battery management systems, and motor control systems, where excessive temperature increase can adversely affect semiconductor devices, system reliability, and safety [1]. Traditional protection schemes may employ microcontroller-based monitoring, which can significantly increase system cost, complexity, and power dissipation [2]. Analog protection circuits provide a trustworthy and economical solution, particularly in applications requiring simplicity and fast response times. Comparators with NTC thermistors provide effective overheating detection without resorting to digital signal processing, and recent research

work emphasizes the need for hardware-based thermal protection in power electronic circuits for fail-safe operation [3]. This paper describes the design and simulation of a temperature protection circuit for a MOSFET using an LM358 comparator to monitor abnormal temperature increase, display warning signals, and automatically switch off the load to avoid damage.

2. Recent Works

A number of thermal protection methods have been described in recent literature. Microcontroller-based temperature protection systems with digital sensors provide high accuracy and flexibility but also demand extra programming and power resources, while smart.

power modules with built-in thermal protection enhance system cost and limit design flexibility [4]. On the other hand, analog thermal protection circuits based on operational amplifiers and thermistors have attracted recent interest because of their simplicity and reliability, with cut off schemes based on operational amplifier comparators used in motor and battery protection circuits. Nevertheless, most of the existing designs do not provide temperature threshold adjustment or simultaneous indication and load isolation. The current design overcomes these problems by providing temperature control, indication, and load isolation in a single compact and cost-effective solution.

3. Proposed Work Explanation

The proposed temperature-controlled protection system includes temperature sensing, comparison logic, indication, and MOSFET-based load isolation stages and is powered by a 12V voltage source to continuously sense the temperature in the vicinity of the protected component. For temperature sensing, an NTC thermistor is employed, which acts as a voltage divider whose output is connected to the non-inverting input of an LM358 comparator, and a potentiometer is connected to the inverting input to set the threshold. Under normal conditions, the output of the comparator maintains the MOSFET in the ON state to enable normal load functioning. However, when the temperature goes above the set threshold, the output of the comparator changes and a transistor driver turns ON a red LED and buzzer while disabling the MOSFET to disconnect the load.

3.1 Mathematical Expressions and Symbols

The thermistor resistance variation with temperature can be approximated using the exponential relationship.

$$R_T = R_0 \exp \left[\beta \left(\frac{1}{T} - \frac{1}{T_0} \right) \right]$$

where R_T is the thermistor resistance at temperature T , R_0 is the nominal resistance at

reference temperature T_0 , and β is the material constant of the thermistor. The comparator switching occurs when the thermistor voltage exceeds the reference voltage set by the potentiometer [5].

4. Results and Discussion

The proposed circuit was simulated using the Proteus software to analyse the circuit's performance for different temperature variations. When the circuit is in normal working conditions, the green LED was always ON, signifying safe operation, and the MOSFET enabled continuous current flow to the load. As the temperature rose beyond the set threshold, a sudden change took place at the comparator output, turning ON the red LED and buzzer simultaneously to indicate a fault, and turning OFF the IRFZ44N MOSFET to disconnect the load. The switching process was rapid and smooth, thus proving the efficiency of the comparator circuit design. In general, the simulation outcome confirms that the circuit design is efficient and consumes less power.

4.1 Preparation of Figures and Tables

All figures and tables are embedded appropriately within the manuscript. Figure 1 shows the proposed temperature-controlled MOSFET protection circuit, while Table 1 summarizes the component specifications selected to ensure reliable detection, fast response, and effective load isolation under overheating conditions.

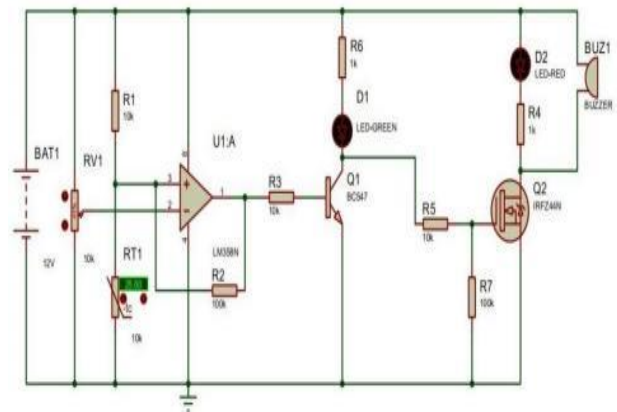

Figure 1: Temperature-controlled MOSFET protection circuit simulated in Proteus

4.1.1 Formatting Tables

Table 1: Component Specifications of the Proposed Circuit

Component	Description / Specification	Purpose
NTC Thermistor	10 kΩ at 25 °C	Temperature sensing
LM358	Dual operational amplifier	Comparator for threshold detection
Potentiometer	10 kΩ	Temperature threshold adjustment
IRFZ44N	N-channel power MOSFET	Load switching and isolation
Green LED	2V,20mA	Normal operation indication
Red LED	2V,20mA	Over-temperature indication
Buzzer	5–12 V active buzzer	Audible alert
Resistors	220 Ω – 10 kΩ	Current limiting and biasing
Power Supply	12V DC	Circuit operation

5. Conclusion

This research work has demonstrated the design and simulation of a temperature-controlled MOSFET protection circuit using an LM358 comparator and an NTC thermistor. The proposed system is capable of monitoring the overheating conditions and automatically disconnecting the load, along with visual and audio notifications. The proposed system uses analog circuits, making it simple and reliable, and does not require complex digital controllers. The proposed system is flexible, simple to design, and can be used in various applications such as power electronics modules, battery protection

circuits, motor drivers, solar charge controllers, and SMPS circuits. Although the proposed system has been simulated, future research work can be carried out on hardware implementation, calibration of the system for higher accuracy, and integration of advanced protection functions.

References

1. A. M. Ali; S. Kumar; R. Singh, Year: 2023, “Thermal Protection Techniques for Power Electronic Devices: A Review”, IEEE Access, Vol: 11, No: 1, pp. 45678 – 45690.
2. Y. Zhang; L. Wang; M. Chen, Year: 2024, “Design of Analog Temperature Monitoring and Protection Circuits for Power Applications”, Microelectronics Reliability, Vol: 145, No: 2, pp. 114982 – 114990.
3. R. Patel; N. Shah; P. Mehta, Year: 2023, “Comparator-Based Over-Temperature Protection Circuit for Battery and Motor Drive Systems”, International Journal of Electronics, Vol: 110, No: 6, pp. 987 – 998.
4. J. Lee; K. Park; S. Kim, Year: 2024, “Low-Cost Hardware Thermal Shutdown Techniques for MOSFET-Based Power Systems”, IEEE Transactions on Power Electronics, Vol: 39, No: 3, pp. 3120 – 3128.
5. S. Franco; A. Malvino, Year: 2022, “Thermistor Characteristics and Temperature Sensing Applications”, IEEE Sensors Journal, Vol: 22, No: 18, pp. 17645 – 17652.