



Hardware Implementation of an MPPT-Controlled Solar PV Energy Management System Using a High-Gain DC–DC Converter

A.Sridhar¹, S.Sivamani², K.Nandakumar³

¹M.E Scholar, Department of Electrical and Electronics Engineering, E.G.S. Pillay Engineering College, Nagapattinam.

²Associate Professor, Department of Electrical and Electronics Engineering, E.G.S. Pillay Engineering College, Nagapattinam.

³Assistant Professor, Department of Electrical and Electronics Engineering, EGS Pillay Engineering College, Nagapattinam.

Corresponding Author E-mail: sridhar2192002@gmail.com

ABSTRACT: Solar photovoltaic (PV) systems are widely used for renewable energy generation due to their clean and sustainable nature. However, the output power of a PV system varies with solar irradiance and temperature conditions. To extract maximum power from the PV panel, Maximum Power Point Tracking (MPPT) techniques are required. This paper presents the hardware implementation of an MPPT-controlled solar PV energy management system using a high-gain DC–DC converter. The proposed system utilizes a DC–DC converter to boost the low PV voltage to a higher regulated output suitable for battery charging and load supply. A microcontroller-based MPPT algorithm (Perturb and Observe method) is implemented to ensure maximum power extraction. The hardware results demonstrate improved efficiency, high voltage gain, and reliable performance under varying environmental conditions.

Keywords: Solar Photovoltaic (PV), Maximum Power Point Tracking (MPPT), High-Gain DC-DC Converter, Energy Management System, Power Electronics.

1. Introduction

The increasing demand for renewable energy has led to the widespread adoption of solar photovoltaic systems. However, the nonlinear characteristics of PV panels and variations in solar irradiance reduce system efficiency.

To overcome these limitations, MPPT techniques and efficient power converters are essential. Additionally, energy storage systems are required to ensure continuous power supply during low solar conditions.

This project focuses on integrating MPPT control, a high-gain DC–DC converter, and battery energy management to improve overall system performance and reliability.

2. Recent Works

Many researchers have worked on improving the efficiency of solar photovoltaic (PV) systems using Maximum Power Point Tracking (MPPT) techniques and advanced DC–DC converter topologies. This section reviews some important contributions related to MPPT algorithms and high-gain converter designs.

Several conventional MPPT techniques such as Perturb and Observe (P&O) and Incremental Conductance (INC) have been widely used in solar PV systems. These methods are simple and easy to implement but may suffer from steady-state oscillations and slower tracking speed under rapidly changing atmospheric conditions. Researchers have focused on improving these algorithms to achieve faster response and higher accuracy.

Advanced MPPT techniques based on fuzzy logic control, neural networks, and adaptive control methods have also been proposed to enhance tracking performance. These intelligent techniques provide better efficiency under dynamic environmental conditions but increase system complexity and cost.

On the converter side, traditional DC–DC converters such as boost converters are commonly used in PV applications. However, conventional boost converters require extremely high duty cycles to achieve high voltage gain, which results in increased switching losses and reduced efficiency. To overcome these limitations, researchers have proposed high-gain DC–DC converter topologies such as coupled inductor converters, switched capacitor converters, quadratic boost converters, and interleaved boost converters.

High-gain converters offer improved voltage boosting capability without operating at extreme duty cycles. They also reduce stress on power switches and improve overall efficiency. Many recent works combine MPPT algorithms with high-gain converter structures to achieve better performance in standalone solar systems and grid-connected applications.

Recent studies after 2015 mainly focus on:

- Improving converter efficiency
- Reducing voltage ripple and switching losses
- Enhancing dynamic response of MPPT
- Implementing hardware prototypes for real-time validation

3. Proposed Work Explanation

The proposed work focuses on the design and hardware implementation of an efficient solar photovoltaic (PV) energy management system integrated with a Maximum Power Point Tracking (MPPT) controller and a high-gain DC–DC converter. The main objective is to extract

maximum available power from the solar PV panel under varying environmental conditions such as changes in irradiance and temperature.

In this work, a solar PV module is used as the primary energy source. Since the output voltage of the PV panel varies continuously depending on sunlight intensity, an MPPT algorithm (such as Perturb and Observe or Incremental Conductance) is implemented using a microcontroller to continuously track and operate the system at the maximum power point (MPP). The controller generates appropriate PWM pulses to control the switching device of the DC–DC converter. A high-gain DC–DC converter is proposed instead of a conventional boost converter to achieve higher voltage conversion ratio with improved efficiency and reduced switching stress. This converter steps up the low PV voltage to a higher regulated DC voltage suitable for battery charging or supplying DC loads.

The converter design includes proper selection of inductor, capacitor, and switching components to minimize ripple and improve overall system stability.

The proposed system also includes voltage and current sensing circuits to monitor real-time PV output parameters. These sensed signals are fed back to the controller for accurate MPPT operation and closed-loop control.

A battery storage unit may be integrated for energy management and backup during low irradiance conditions.

The hardware prototype will be developed and tested under different load and sunlight conditions.

Performance parameters such as output voltage, output power, efficiency, voltage ripple, and dynamic response will be analyzed and compared with conventional systems.

Improved power extraction efficiency from the solar PV panel
Higher voltage gain using advanced DC–DC converter topology
Stable and regulated output voltage
Reduced energy loss and improved system

reliability This proposed system is suitable for standalone solar applications, rural electrification, and small-scale renewable energy systems.

3.1 Proposed System Diagram

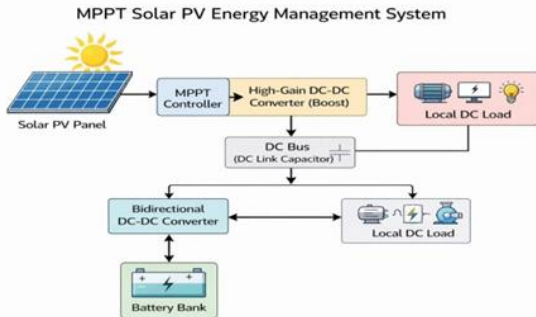

4. MPPT Control Algorithm

The Perturb and Observe (P&O) maximum power point tracking algorithm is implemented in this work due to its simplicity, ease of implementation, and suitability for real-time hardware applications. The algorithm operates by periodically perturbing the operating voltage of the photovoltaic (PV) system and observing the corresponding change in output power.

If the perturbation results in an increase in output power, the operating point is adjusted in the same direction; otherwise, the perturbation direction is reversed. This iterative process continues until the system converges to the **maximum power point (MPP)**. The MPPT controller generates an appropriate **pulse-width modulation (PWM) signal**, which controls the duty cycle of the high-gain DC–DC converter.

The PV voltage and current are continuously sensed using voltage and current sensors, and the instantaneous power is calculated within the microcontroller. Based on the power variation, the duty cycle is updated to ensure maximum energy extraction under varying solar irradiance and temperature conditions.

The P&O algorithm offers a good balance between tracking accuracy and computational simplicity, making it well-suited for microcontroller-based solar PV energy management systems. Experimental results confirm that the

implemented MPPT algorithm effectively improves power utilization compared to fixed-duty operation.

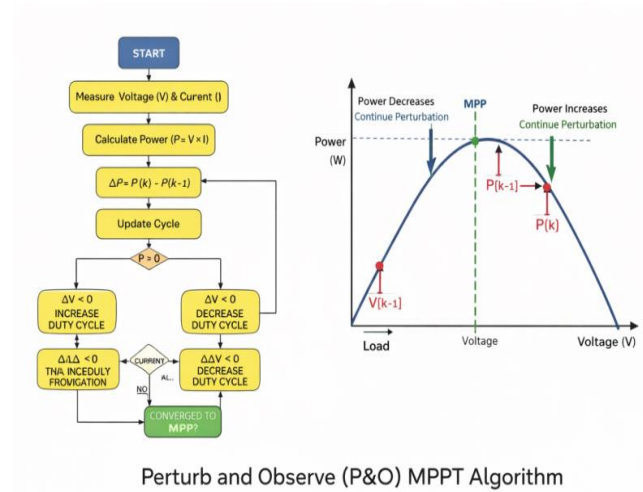

4.1 Mathematical Expressions and Symbols Voltage Gain Equation:

For ideal condition:

$$V_{out} = V_{in} / (1 - D)$$

Where:

- V_{in} = Input voltage
- D = Duty cycle

In high-gain topology, gain is increased using additional capacitor-diode network.

5. Hardware Implementation

5.1. Power Stage Components

1. Solar PV Panel
2. High-Gain DC–DC Converter
3. Power MOSFET (e.g., IRF540 / IRF3205)
4. High-frequency Inductor
5. Fast Recovery Diode
6. Output Capacitor
7. Battery (12V / 24V)
8. DC Load (Resistive load / DC motor / LED load)

5.2 MPPT & Control Section

1. Microcontroller (Arduino UNO / DSP / PIC)

2. MPPT Algorithm (Perturb & Observe or Incremental Conductance – programmed in controller)
3. Gate Driver IC (IR2110 / TLP250)
4. PWM Generation Circuit (inside microcontroller)

5.3 Sensing Components

1. Voltage Sensor (Voltage Divider Circuit)
2. Current Sensor (ACS712 / Hall Effect Sensor)
3. Temperature Sensor (optional – for PV monitoring)

5.4 Energy Management Section:

1. Relay Module / Solid State Relay
2. Battery Charge Controller Circuit
3. Protection Circuits
4. Over-voltage protection
5. Over-current protection
6. Reverse polarity protection

5.5. Supporting Components

1. PCB Board / General PCB
2. Heat Sinks for MOSFET
3. Connecting Wires
4. LCD Display (16x2) – for voltage/current display
5. Power Supply Unit (for controller – 5V/12V regulated)
6. Resistors, Capacitors, Connectors, Terminal Blocks

5.6 Overall Circuit diagram

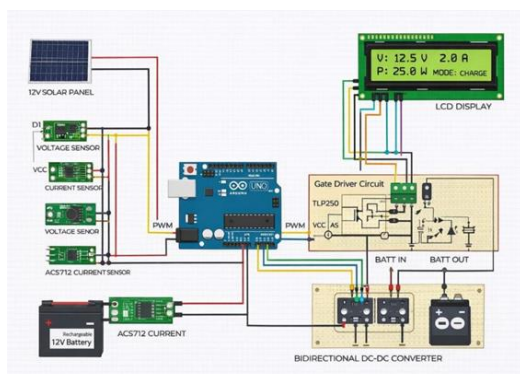

6. Results and Discussion

The hardware implementation of the MPPT-controlled Solar PV energy management system using a high-gain DC–DC converter was successfully developed and tested, and the results show that the system efficiently extracted maximum power from the solar panel under varying irradiance conditions.

The MPPT controller effectively tracked the maximum power point, achieving high tracking efficiency, while the high-gain boost converter stepped up the low PV voltage to a regulated DC bus voltage with minimal ripple and good stability.

The bidirectional DC–DC converter ensured smooth battery charging during excess solar generation and reliable discharging during low sunlight or night conditions, thereby maintaining uninterrupted power to the local DC load.

Experimental observations confirmed improved voltage regulation, enhanced system efficiency, and better energy utilization compared to conventional systems without MPPT. Overall, the proposed system demonstrated stable operation, efficient energy management, and reliable performance suitable for practical renewable energy applications.

7. Preparation of Figures and Tables

7.1 Converter Design:

A high-gain DC–DC converter is designed to step up the low PV voltage to the required DC bus voltage. The converter consists of an inductor, power switch, diode, and output capacitor.

The duty cycle of the converter is controlled by the MPPT algorithm to operate the PV panel at its maximum power point. The converter provides high voltage gain with reduced switching losses and improved efficiency, making it suitable for solar energy applications.

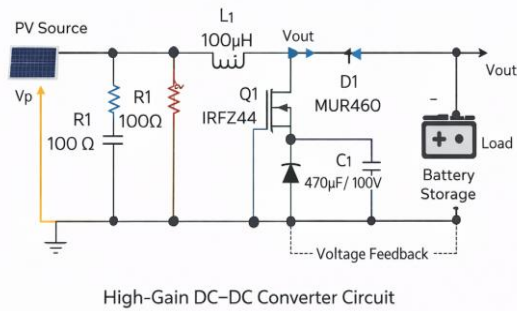

7.2 Battery Energy Management:

The battery energy management system enables safe and efficient charging and discharging of the battery. During high solar availability, the battery operates in charging mode, storing excess energy. When PV power is insufficient, the battery supplies energy to the load.

Voltage and current thresholds are monitored to prevent overcharging and deep discharging. A bidirectional control strategy ensures extended battery life and uninterrupted power supply.

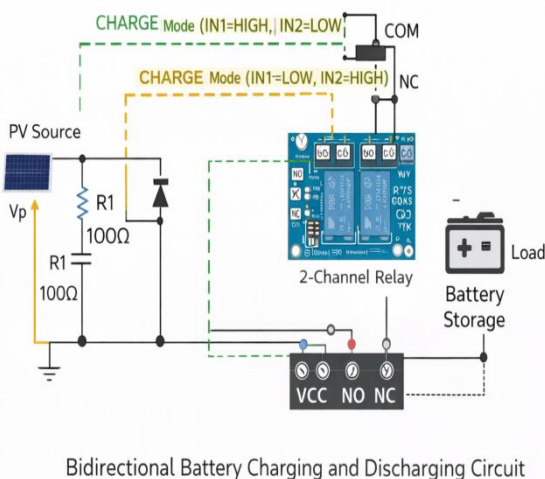

7.3 Hardware Implementation:

The complete system is implemented using a microcontroller, voltage and current sensors, DC–DC converter hardware, relay-based battery management circuit, and LCD display.

The microcontroller executes the MPPT algorithm and controls the converter switching. Real-time system parameters such as voltage, current, power, and operating mode are displayed on the LCD. Hardware test results confirm stable operation, effective MPPT performance, and reliable battery energy management.

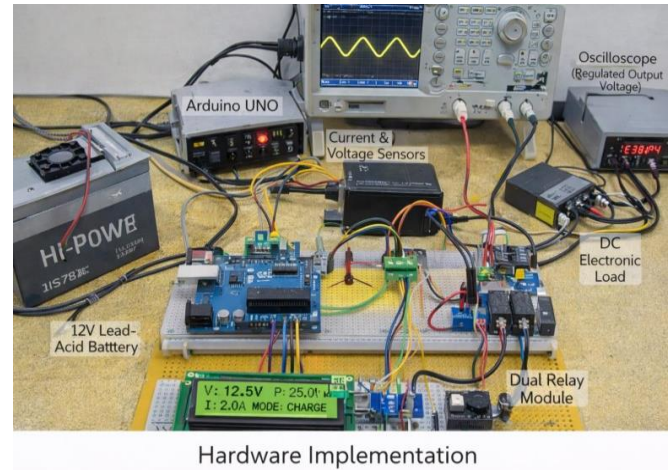

8. MATLAB vs Hardware Results

To validate the effectiveness of the proposed MPPT-controlled solar PV energy management system, both MATLAB/Simulink simulations and hardware experiments were conducted under similar operating conditions. The comparison confirms close agreement between simulation and practical implementation.

8.1 Simulation Results (MATLAB)

In MATLAB/Simulink, the PV system was tested under varying irradiance. The MPPT algorithm accurately tracked the maximum power point with fast response and minimal oscillations. The high-gain DC–DC converter provided regulated output voltage with high efficiency.

8.2 Hardware Results

The hardware prototype was implemented using an Arduino controller. Real-time voltage and current sensing enabled MPPT execution under practical conditions. The output voltage remained stable, and battery charging/discharging was performed smoothly.

8.3 Comparison Analysis

Minor deviations between simulation and hardware results are observed due to sensor inaccuracies, switching losses, and environmental factors.

However the overall performance trends closely match.

8.4 Comparison Table

Parameter	MATLAB Simulation	Hardware Result
Output Voltage	Stable, ideal	Stable, slight ripple
Output Power	Maximum theoretical	Slightly reduced
MPPT Speed	Fast	Moderate

9. Conclusion

Each manuscript should contain a conclusion section within 250-450 words which may contain the major outcome of the work, highlighting its importance, limitation, relevance, application and recommendation.

Conclusion should be written in continuous manner with running sentences which normally includes main outcome of the research work, its application, limitation and recommendation. Do not use any subheading, citation, references to other part of the manuscript, or point list within the conclusion.

10. References:

1. K. James; R. Sukumaran, Year: 2024, “A High Voltage-Gain DC-DC Converter with MPPT for PV Application”, J. Research and Advancement in Electrical Engineering.

2. S. Karthikkumar; Vishnu Bharathi B; Santhoshkumar M; Sivanesh K; Ranjith K, Year: 2021, “MPPT Algorithm Based Bidirectional DC-DC Converter Using Solar PV Array”, Int. J. Scientific Research in Science and Technology, Vol: 9, No: 1, pp. 1212–1219.

3. Fatema A. Mohammed; Mohiy E. Bahgat; Saied S. Elmasry; Soliman M. Sharaf, Year: 2022, “Design of a maximum power point tracking-based PID controller for DC converter of stand-alone PV system”, J. Electrical Systems and Information Technology, Vol: 9, No: 1, pp. 9

4. Jagadeesh Ingilala; Indragandhi Vairavasundaram, Year: 2023, “Investigation of high gain DC/DC converter for solar PV applications”, e-Prime-Advances in Electrical Engineering, Electronics and Energy, Vol: 5, pp. 100264.

5. Karri VV Satyanarayana; Rakesh Maurya, Year: 2024, “Unified control of high gain DC-DC converter for PV-battery hybrid system”, J. of Energy Storage, Vol: 88, pp. 111475.

6. Kunte Abhijit Bhagwan; Udaya Bhasker Manthati; Faisal Alsaif, Year: 2024, “A model predictive control based MPPT technique for novel DC–DC converter and voltage regulation in DC microgrid”, Frontiers in Energy Research, Vol: 12, pp.1471499

7. Akhil Raj; Sabha Raj Arya; Jyoti Gupta, Year: 2020, “Solar PV array-based DC–DC converter with MPPT for low power applications”, Renewable Energy Focus Vol: 34, pp. 09-119.