



AI and IoT-Based Illegal Mining and Deforestation Detection

S.Yamuna¹, K.Subalakshmi², G.Tharshini³, K.Vidhya⁴, R. Mahalakshmi⁵

¹Department of Electronics and Communication Engineering, MRK Institute of Technology, Anna University

²Department of Electronics and Communication Engineering, MRK Institute of Technology, Anna University

³Department of Electronics and Communication Engineering, MRK Institute of Technology, Anna University

⁴Department of Electronics and Communication Engineering, MRK Institute of Technology, Anna University

⁵Assistant Professor, Department of Electronics and Communication Engineering, M.R.K. Institute of Technology, Kattumannarkovil

¹Corresponding Author E-mail: yamunas310305@gmail.com

ABSTRACT: Forests and remote areas require continuous monitoring to prevent illegal activities and environmental hazards, but regular human supervision is difficult due to their large coverage and limited infrastructure. This research proposes a solar-powered smart monitoring system designed to improve protection and surveillance in such regions. The system uses multiple sensors to detect abnormal events in real time. A vibration sensor detects unusual ground disturbances caused by activities such as tree cutting or mining, and when abnormal vibration is detected, the system activates a camera to capture images of the surrounding area for analysis. An infrared sensor is used to detect unauthorized human or vehicle movement, while a flame sensor identifies early signs of fire to prevent forest fires. The sensor data are processed by a microcontroller that controls the entire system and evaluates the detected conditions. When an abnormal event occurs, an alert message is sent to the authorities using a Global System for Mobile Communication module. The system status is displayed on a liquid crystal display and also monitored remotely through an Internet of Things platform. Since remote forest areas often lack reliable electricity, the system operates using solar power. The proposed system provides a reliable and cost-effective solution for early detection of threats and improved forest protection.

Keywords: Forest monitoring system, vibration detection, fire detection, Internet of Things, solar-powered surveillance.

1. Introduction

Forests play a vital role in maintaining ecological balance, preserving biodiversity, and supporting environmental sustainability. However, forest areas are increasingly threatened by illegal activities such as tree cutting, unauthorized human intrusion, and forest fires. Monitoring these large and remote regions continuously is challenging due to limited infrastructure and the lack of reliable power supply. Traditional monitoring methods mainly rely on manual patrols, which are time-consuming and often unable to detect threats at an early stage.

Therefore, an automated monitoring system is required to detect abnormal activities and environmental hazards in real time.

Recent advancements in sensor technology and Internet of Things (IoT) systems have enabled the development of smart environmental monitoring solutions. These systems use sensors and wireless communication technologies to monitor environmental parameters and send alerts when abnormal conditions are detected [1]. Solar-powered monitoring systems have also gained significant attention for deployment in remote forest areas where conventional electricity is

unavailable [2]. However, many existing systems focus on detecting a single type of threat, such as fire detection or motion detection. Therefore, a multi-sensor monitoring system capable of detecting vibration, intrusion, and fire hazards simultaneously is required to enhance forest protection and enable early threat detection [3].

2. Recent Works

Recent research has focused on developing smart forest monitoring systems using sensors and Internet of Things technologies. These systems integrate sensors such as temperature, smoke, motion, vibration, and flame sensors with microcontrollers to monitor forest environments and detect abnormal events in real time. When abnormal conditions are detected, alert messages are transmitted to authorities through wireless communication networks and IoT platforms for quick response [1].

Some studies have also integrated monitoring systems with camera modules and computer-based image processing to improve surveillance and identify illegal activities such as tree cutting and intrusion. These approaches enable real-time monitoring and visual verification of detected events [2]. In addition, solar-powered IoT frameworks have been proposed to ensure continuous monitoring in remote forest regions where conventional power supply is unavailable [3].

Although these systems provide effective monitoring solutions, many existing approaches focus mainly on single-parameter detection such as fire monitoring. Therefore, a multi-sensor - based monitoring system capable of detecting vibration, human intrusion, and fire hazards simultaneously is required to improve forest protection and early threat detection [4].

3. Proposed Work Explanation

The proposed system is a solar-powered smart monitoring system designed to protect forests and remote areas from illegal activities and

environmental hazards. It continuously monitors the environment and detects abnormal events such as illegal tree cutting, unauthorized human intrusion, and early fire hazards. The system is developed using multiple sensors, a microcontroller, a communication module, and a camera unit to provide real-time monitoring and alert generation.

A vibration sensor is used to detect abnormal ground disturbances caused by activities such as tree cutting, mining, or heavy movement. When the sensed vibration exceeds a predefined threshold value, the system identifies it as suspicious activity and activates a camera to capture the surrounding scene. An infrared sensor is used to detect human or vehicle movement in restricted forest zones, while a flame sensor is used to identify the early presence of fire.

The ESP32 microcontroller acts as the central control unit of the system. It continuously collects data from the connected sensors, processes the information, and determines the appropriate response. When any abnormal condition is detected, the system sends alert messages to authorities through a GSM module. The current status of the system is displayed on an LCD screen for local monitoring, while sensor data can also be transmitted to a PC or Internet of Things platform for remote observation and analysis.

Since forests and remote locations often do not have a reliable electricity supply, the entire system is powered using solar energy, making it suitable for long-term deployment. By combining multi-sensor monitoring, image capture, wireless communication, and renewable power, the proposed system provides a reliable, cost-effective, and efficient solution for forest protection and environmental monitoring.

3.1 Mathematical Expressions and Symbols

In the proposed system, the vibration sensor continuously measures ground vibrations in the

forest area. The sensor output value is transmitted to the microcontroller and compared with a predefined threshold value to detect abnormal activities such as tree cutting, mining, or heavy movement. When the measured vibration value exceeds the threshold, the system identifies it as an abnormal event and triggers further actions such as activating the camera and sending alert messages to authorities.

The vibration detection condition can be represented as

$$V_{sensor} > V_{threshold} \tag{1}$$

where V_{sensor} represents the vibration sensor output value and $V_{threshold}$ represents the predefined threshold value. If the sensor value exceeds the threshold value, the system interprets it as abnormal vibration.

To improve reliability, the average vibration value can also be calculated using multiple sensor readings as

$$V_{avg} = \frac{1}{n} \sum_{i=1}^n V_i \tag{2}$$

where V_i represents individual vibration readings and n represents the total number of samples. The average value helps reduce noise and provides a more stable measurement of vibration activity.

In addition, the alert condition for the monitoring system can be expressed as

$$Alert = \begin{cases} 1, & V_{sensor} > V_{threshold} \\ 0, & V_{sensor} \leq V_{threshold} \end{cases} \tag{3}$$

where **Alert = 1** indicates that abnormal activity is detected and the system activates the camera and sends notifications, while **Alert = 0** indicates normal environmental conditions.

4. Results and Discussion

The proposed solar-powered smart monitoring system was tested to evaluate its ability to detect abnormal activities in forest and remote areas. The vibration sensor successfully detected ground disturbances caused by activities such as tree cutting or heavy movement. When the

vibration value exceeded the predefined threshold, the system identified it as an abnormal event and activated the monitoring process. The infrared sensor detected human movement in restricted areas, while the flame sensor identified fire conditions at an early stage.

The sensor data was processed by the microcontroller and transmitted for monitoring. The system showed reliable performance in detecting different types of threats. Compared with existing systems that monitor only a single parameter, the proposed system integrates multiple sensors, improving detection accuracy and providing a more effective solution for forest protection and early threat detection.

4.1 Preparation of Figures and Tables

Sensor	Function	Output Type	Operating Voltage
Vibration Sensor	Detects ground vibration from tree cutting or mining	Digital / Analog	3.3V – 5V
IR Sensor	Detects human or vehicle movement	Digital	3.3V – 5V
Flame Sensor	Detects fire or flame in forest area	Analog	3.3V – 5V

Table 2: System Components

Component	Description	Purpose
ESP32	Microcontroller with Wi-Fi capability	Processes sensor data
Camera Module	Image capturing device	Captures images during abnormal events
GSM Module	Communication module	Sends alert messages to authorities
LCD Display	Display module	Shows system status locally
Solar Panel	Renewable energy source	Provides power to the system

Table 3: System Detection Conditions

Event	Sensor Used	Condition	System Response
-------	-------------	-----------	-----------------

Event	Sensor Used	Condition	System Response
Tree Cutting	Vibration Sensor	Value > Threshold	Camera activated
Human Intrusion	IR Sensor	Motion detected	Alert generated
Fire Hazard	Flame Sensor	Flame detected	Fire alert sent

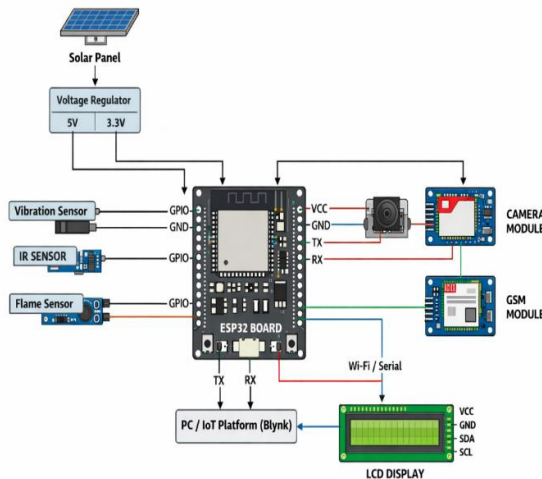

Figures and tables are included in the manuscript to clearly present the design and operation of the proposed forest monitoring system. They are placed at appropriate positions in the manuscript and numbered sequentially with descriptive captions. In this work, Figure 1 shows the circuit diagram of the solar-powered monitoring system, including the solar panel, voltage regulator, ESP32 microcontroller, vibration sensor, infrared sensor, flame sensor, camera module, GSM module, LCD display, and IoT platform. The sensors detect ground vibration, human movement, and fire conditions, while the ESP32 processes the data, activates the camera during abnormal vibration, and sends alerts through the GSM module. Tables are used to present component specifications and system parameters, improving the clarity and understanding of the proposed system.

5. Conclusion

The proposed solar-powered smart monitoring system improves the protection of forests and

remote areas by detecting abnormal activities and environmental hazards. The system uses vibration, infrared, and flame sensors to monitor ground disturbances, human movement, and fire conditions. When abnormal vibration is detected, a camera is activated and alerts are sent to authorities. The ESP32 processes the sensor data and updates the monitoring platform. Solar power enables continuous operation in remote areas without electricity. The results show that the system can effectively detect threats and provide early warnings, making it a reliable and cost-effective solution for forest monitoring and environmental protection.

References

1. S. Yamuna; K. Subalakshmi; G.Tharshini; K. Vidhya, Year: 2026, “AI and IoT-Based Illegal Mining and Deforestation Detection”, International Journal of Advanced Trends in Engineering and Management (ISSN: 2583-7052), indexed in Google Scholar, and assigned a DOI via Crossref.
2. A. Khushal; A. Kishore, Year: 2025, “Real Time Smart Forest Fire Detection and Monitoring System Using IoT and Machine Learning”, In 2024 8th International Conference on Computational System and Information Technology for Sustainable Solutions (CSITSS), pp. 1-5.
3. “AI-Powered Forest Surveillance Systems: Identifying and Preventing Illegal Logging”, ResearchGate, Mar. 2025.
4. Alireza Etaati; Mostafa Bastam; Ehsan Ataie, Year: 2024, “Smart Forest Monitoring: A Novel Internet of Things Framework”, IET Digital Library, Vol: 13, No. 5-6, pp. 528-545.
5. J. Kirbakaran; R. Dinesh kumar; P. M. Elangkumaran; B. Kavinkumar, Year: 2026, “Design and Implementation of Forest Fire Detection Using Artificial Intelligence”, International Research Journal of Advanced Engineering and Technology, Vol: 4, No. 1, pp. 344-348.

6. Iulia Diana Arion; Irina M. Morar; Alina M. Truta; Ioan Aurel Chereches; Vlad Ilie Isarie; Felix H. Arion, Year: 2025, "Internet of Things (IoT)-Based Applications in Smart Forestry", *Forests*, Vol: 17, No. 1, pp. 44.
7. C. Arulstephen; R. K. Raghulsharma; Ebenezer Abishek; P. Kumar, Year: 2025, "Wireless Sensor Based Monitoring System for Forest Tree Poaching and Fire Detection", Vol: 7, No: 10, pp.14419.
8. Allanki Sanyasi Rao; N Anusha; Syed Nehal; K Maheshwara Chary; D Sharan Kumar, Year: 2024, "Forest Fire Detection Using GSM Module", *International Journal of Electronics and Communication Engineering*, Vol: 14, No: 04, pp. 260-266.