



Article Title: Advanced IoT Based Combined Remote E-Health Monitoring and Home Testing Using Arduino Uno

Advanced IoT Based Combined Remote E-Health Monitoring and Home Testing Using Arduino Uno

B. Mahammed Raffi¹, A. Geethanjali², C. Sarathsai³, B. Rajesh⁴,
K. Tharun Kumar⁵, K. Nithin Reddy⁶

²Assistant Professor, Department of Electronics and Communication Engineering,
Sri Venkatesa Perumal College of Engineering and Technology, Puttur, AP, India.

^{1,3,4,5,6}UG Students, Department of Electronics and Communication Engineering,
Sri Venkatesa Perumal College of Engineering and Technology, Puttur, AP, India.

Abstract

The advancement of Internet of Things (IoT) technology has revolutionized the healthcare sector by enabling remote health monitoring and home testing, enhancing patient care, and improving healthcare accessibility. This paper proposes an advanced IoT-based system utilizing Arduino Uno microcontroller for combined remote e-health monitoring and home testing. The system integrates various sensors and modules to monitor vital health parameters such as heart rate, temperature, and oxygen saturation. The Arduino Uno acts as the central processing unit, collecting data from the sensors and transmitting it wirelessly to a cloud-based platform through Wi-Fi. The cloud platform stores and analyses the data, providing real-time monitoring for healthcare providers and patients. Moreover, the system incorporates a user-friendly interface accessible via a mobile application or web portal, allowing patients to view their health data, receive notifications/alerts for critical conditions, and communicate with healthcare professionals remotely. The system offers several advantages like Continuous monitoring, Convenience, Accessibility, Data-driven insights. The proposed advanced IoT-based combined remote e-health monitoring and home testing system using Arduino Uno presents a promising solution for enhancing healthcare delivery, promoting preventive care, and empowering patients to take control of their health.

Keywords: Arduino Uno, IoT (Internet of Things), Home testing, NODE MCU (esp8266), Healthcare, Remote monitoring, Home testing, Sensors, Real-time monitoring, Continuous monitoring, Healthcare delivery, Preventive care, Patient empowerment.

1. Introduction

An addition to a hospital's medical system, a remote health monitoring system allows for the remote monitoring of a patient's vital signs. Hospitals were the only places to find detecting systems in the past. These systems had enormous, intricate circuitry that consumed a lot of electricity. Sensors and microcontrollers with reduced dimensions, faster operation, lower power consumption, and lower costs are now possible thanks to ongoing advancements in the semiconductor technology sector.



Article Title: Advanced IoT Based Combined Remote E-Health Monitoring and Home Testing Using Arduino Uno

Healthcare providers may now remotely monitor patients' health state in real-time, independent of their physical location, thanks to its flexibility and ease of use in conjunction with IoT technology. In addition to improving healthcare delivery efficiency, this novel strategy encourages patient comfort and autonomy.

The core component of this remote health monitoring system is an Arduino Uno, which interfaces with a variety of sensors to record crucial health information including temperature, blood pressure, heart rate, and more. To guarantee thorough observation, these sensors are positioned strategically on the patient's body or in their immediate surroundings.

The Arduino Uno sends the gathered health data to a secure cloud-based platform or a dedicated server architecture via seamless connectivity choices like Wi-Fi, Bluetooth, or cellular networks made possible by IoT technology. In this case, complex algorithms evaluate the data in real-time, identifying any departures from the norm and producing alarms that require quick action.

Healthcare professionals can remotely monitor the health status of several patients at once if they have access to the remote monitoring platform through mobile applications or web-based dashboards. This realtime visibility facilitates proactive management of chronic illnesses, treatment plan optimization, and prompt intervention in the event of an emergency.

Furthermore, the incorporation of wearable with Internet of Things capabilities broadens the scope of remote health monitoring outside hospital walls.

While designing and implementing this Internet of Things-based healthcare service, security and privacy were given top priority. Both patients and healthcare professionals have more faith in the system because of the robust encryption mechanisms, stringent access controls, and compliance with legal requirements that guarantee the confidentiality and integrity of patient data. To sum up, the combination of the Arduino Uno and IoT technology signals the beginning of a new era in the provision of healthcare, one that is marked by proactive intervention, ongoing remote monitoring, and custom care. We can reshape the medical landscape and usher in a time where patient-centricity and optimal health outcomes are the norm by harnessing the power of innovation.

2. Objective

The objective is to empower individuals to take proactive control of their health by leveraging the capabilities of IOT technology and Arduino Uno to create a comprehensive e-health monitoring and home testing solution. This solution aims to provide users with the ability to remotely monitor their vital health parameters and conduct essential health tests from the comfort of their homes. By enabling easy access to real-time health data and testing capabilities, the objective is to promote early detection of health issues, facilitate timely interventions, and ultimately improve overall health outcomes for individuals. Additionally, the solution strives to enhance convenience, accessibility, and affordability of healthcare services,



Article Title: Advanced IoT Based Combined Remote E-Health Monitoring and Home Testing Using Arduino Uno

particularly for those in remote or underserved areas. Overall, the objective is to empower individuals to actively engage in their own healthcare management and promote a proactive approach to maintaining wellness and managing chronic conditions.

3. Existing System

It might not be able to continuously monitor patients' conditions in a hospital where nurses and doctors must physically walk from one patient to another for health checks. Because of this, it is difficult to identify any urgent situations unless the nurse or doctor assesses the patient's condition at that same moment. The doctors may find this difficult to handle given how many patients they have to attend to in the hospital. Additionally, patients are frequently asleep and unable to touch an emergency alert button when they have a medical emergency.

3.1 Drawbacks

- Lack of Automated Systems
- Privacy and Security Concerns
- User Adoption and Engagement
- Invasive Connection Requirements
- Cost and High power supply

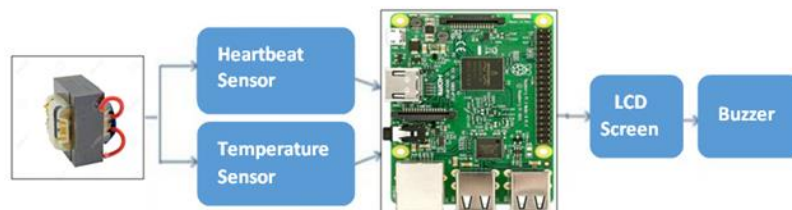

Figure 1: Block diagram

The Existing system having the transformer which is used as power supply, but it will produce more heat and consume high power. The raspberry pi connects with sensors and display which is difficult to implement the system.

4. Proposed System

Enabling our system to continuously monitor patient's vital signs and detect problems is the project's goal. Staff's in medicine receive access to the monitored data. The medical staff is informed about the abnormal parameter by the system when it detects irregularities. Diminishes the requirement for the medical staff to perform manual monitoring. To transmit data from sensors to the Ubidots cloud platform, our suggested system employs an Arduino board equipped with an esp8266. Using the esp8266 module, which has the API key from the Things Peak website programmed into it, Arduino has been programmed. Users with any number of Ubidots access keys can view the medical record stored on the device.



Article Title: Advanced IoT Based Combined Remote E-Health Monitoring and Home Testing Using Arduino Uno

The purpose of the health monitoring sensors is data acquisition, or the collection of health-related data. Wireless data transmission via the internet can be facilitated by controller communication. The server has processed the data. Every piece of data is gathered and combined at the server. Data management, or websites, can display health-related information. The three phases of the Internet of Things work flow are collect, evaluate, and act. Collecting data from sensors situated in faraway areas is the first step in the process. UBIDOTS servers are used to solve this issue. Analyzing the information gathered is the second phase. Real-time data monitoring allows for the visualization of the data.

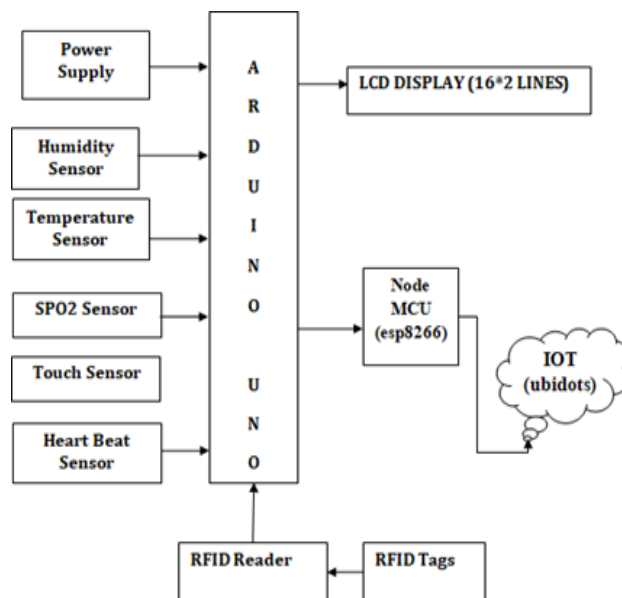

Figure 2: Proposed Architecture

Figure illustrates how the system operates. The data gathered from the sensor is examined, if unusual activity is found, the emergency protocol is triggered to notify the physician about the patient's condition. Thus, it lessens the severity of hospital circumstances. All of this may be remotely monitored from anywhere in the world with the aid of the Ubidots server.

5. System Components

The proposed system consists of various blocks for different methodologies that is discussed below

5.1 Arduino Uno

An open-source programmable circuit board called Arduino is built on top of user-friendly hardware and software. It revolves around the ATmega328. It includes a reset button, a power connector, an ICSP header, six analog inputs, 14 digital input/output pins, a USB port, and a power jack. The board can be powered by plugging in an ACDC power source or using a USB cable to connect it to the laptop.



Article Title: Advanced IoT Based Combined Remote E-Health Monitoring and Home Testing Using Arduino Uno



Figure a: *Arduino Uno*

5.2 ATMEGA328P-PU With Arduino Boot Loader

The name says everything on this one. An Atmega328 in DIP bundle, pre-stacked with the Arduino (16MHz) Boot loader. To get this chip working with Arduino IDE, you will require an outside 16MHz significant stone or resonator, a 5V supply, and a serial association.

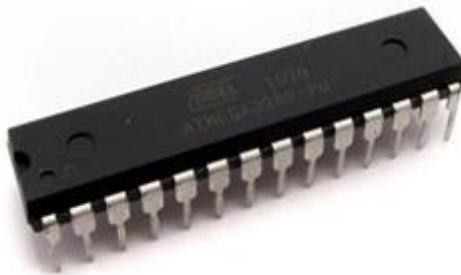

Figure b: *Atmega328P-PU*

5.3 NODE MCU

Node MCU is a versatile open-source firmware and development kit based on the ESP8266 Wi-Fi module, tailored for Internet of Things (IoT) applications. Featuring an onboard Wi-Fi module and Lua scripting language support. Its GPIO pins facilitate seamless integration with a plethora of sensors, actuators, and peripherals, enabling a wide array of functionalities. With USB connectivity for power and communication, It offers straightforward programming and debugging capabilities.



Figure c: *Node MCU*



Article Title: Advanced IoT Based Combined Remote E-Health Monitoring and Home Testing Using Arduino Uno

5.4 Pulse Oximeter (MAX30100):

The heart rate measure kit can be used to monitor heart rate of maternal. The result can be displayed on a screen via the serial port. It is designed to give digital output of heart beat when a finger is placed on it. Operating voltage is +5V regulated and the operating current 100mA. These sensors are able to show the SPO2 of the patient.



Figure d: *Pulse oximeter (max30100)*

5.5 Temperature/Humidity Sensor (DHT-11)

The temperature and humidity of the atmosphere are measured using a Temperature Sensor (DHT-11). It separates a digital signal on the data pin by measuring the ambient air using a thermistor and a capacitive humidity sensor. The electrical resistance between two electrodes is measured by the DHT-11 to determine relative humidity.

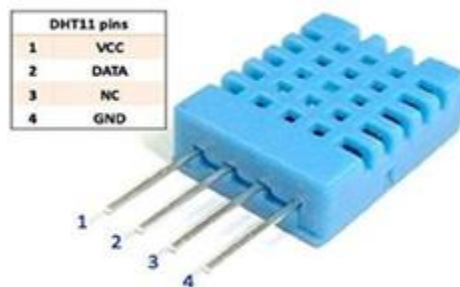

Figure e: *Temperature/Humidity Sensor (DHT-11)*

5.6 LCD Display

LCD stands for liquid crystal display, which is used to show the status of an application, displaying values, debugging a program, etc. A 16x2 LCD means it can display 16 characters per line and there are 2 such lines. In this LCD each character is displayed in 5x7 pixel matrix. The 16 x 2 intelligent alphanumeric dot matrix displays is capable of displaying 224 different characters and symbols.



Article Title: Advanced IoT Based Combined Remote E-Health Monitoring and Home Testing Using Arduino Uno

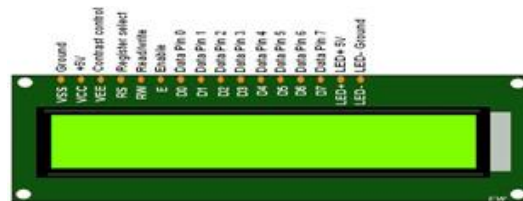

Figure f: 16x2 LCD

6. Implementation

The system is working through the IOT-based. The sensors will sense the data of the victim's then the IOT will send the data to the database when the system is connected to the Wi-Fi.

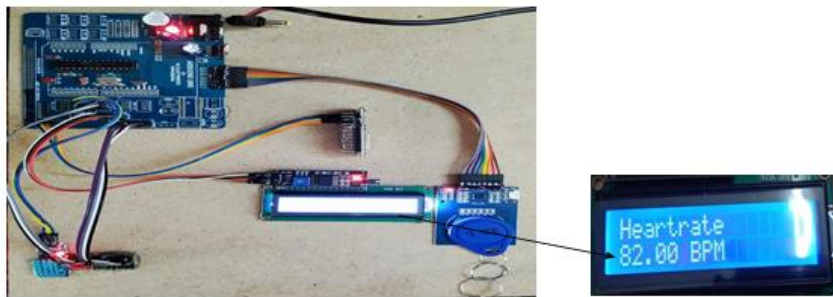

Figure 3: System Implementation

The Fig-3 shows the power supply activates the circuit, enabling it to function. The touch sensor, heartbeat sensor, Spo2 and temperature sensor serve as inputs, detecting the victim's condition during critical situations. These sensors provide crucial information about the victim's state, facilitating appropriate responses or interventions. These sensors are connected to the Arduino with the help of cable wires as well as display. The display gets the data and that will be displayed to the user and sending to IOT. The RF id is used to store the data of the particular user that can be separated in the database. Using the RF id tags are working as authentication of the person used to separates the data of the user.

7. Result

Case-1

Input

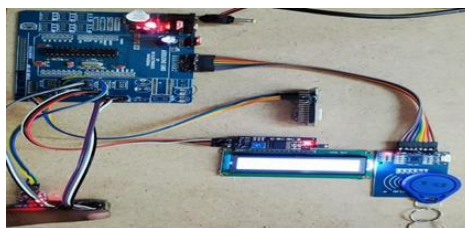

Figure 4: Input of User-1

The Fig-4 shows taking input from the user-1 at first by using RF id tag-1 and created separate database for tag-1. The user will use finger to know the required results like temperature, heart



Article Title: Advanced IoT Based Combined Remote E-Health Monitoring and Home Testing Using Arduino Uno

rate, spo2 and humidity. Then it will send data to IoT through wifi. If we get any issues we need to press reset button, which is placed at Node Mcu.

Output



Figure 4a: *Output of User-1*

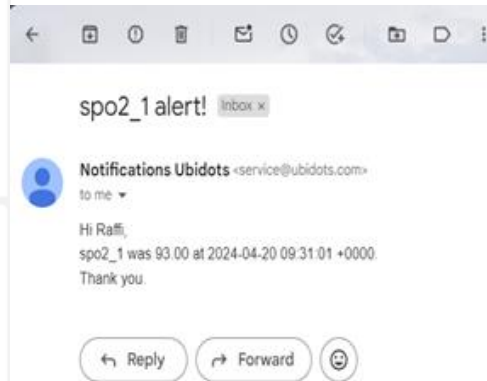

Figure 4b: *Notification alert*

In Fig-4a and Fig-4b represents the output of the system can be viewed on various devices such as computers, laptops or mobiles phones. Users can access the data on the UBI DOTS open-source platform by logging in with the User.

This allows them to monitor and analyze real-time readings from the sensors. The collected data of the user-1 will be displayed and user can be get notified though the E-mail.

Case-2

Input

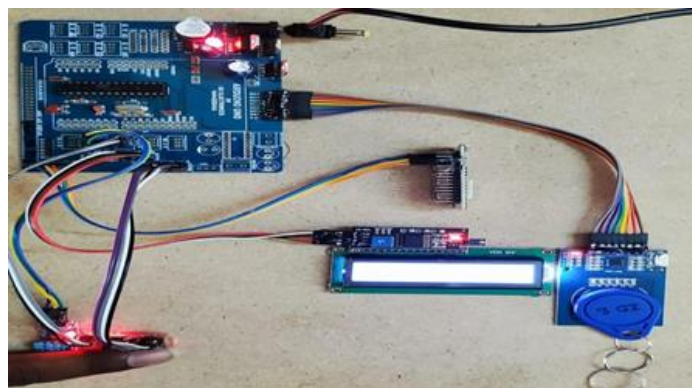

Figure 5: *Input of User-2*

The Fig-5 shows taking input from the user-2 at first by using RF id tag-2 and created separate database for tag-1. The user will use finger to know the required results like temperature, heart rate, spo2 and humidity. Then it will send data to IoT through wifi. If we get any issues we need to press reset button, which is placed at Node Mcu.



Article Title: Advanced IoT Based Combined Remote E-Health Monitoring and Home Testing Using Arduino Uno

Output

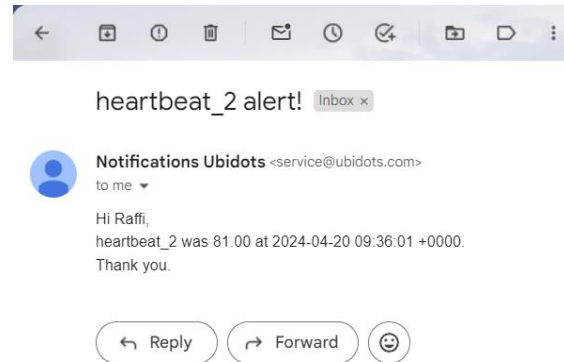
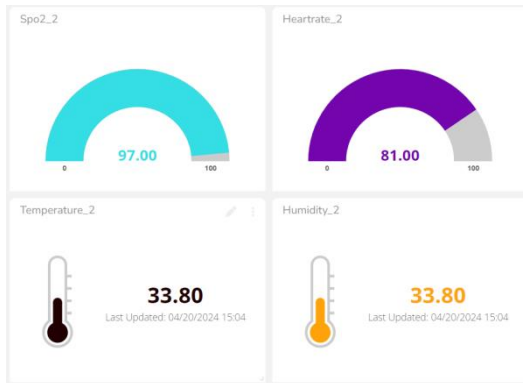

Figure 5a: Output of User-2

Figure 5b: Notification alert

In Fig-5a and Fig-5b represents the output of the system can be viewed on various devices such as computers, laptops or mobiles phones. Users can access the data on the UBI DOTS open-source platform by logging in with the User.

This allows them to monitor and analyze real-time readings from the sensors. The collected data of the user-2 will be displayed and user can be get notified though the E-mail.

8. Applications and Advantages

8.1 Applications

- IoT Healthcare is the most demanding field in the medical area. This project is for, elderly people in our home.
- For the senior citizen living alone or living with 1 or 2 members.
- This work really proves helpful when family members need to go out for some emergency work.

8.2 Advantages

- IOT Monitoring proves really helpful when we need to monitor & record and keep track of changes in the health parameters of the patient over a period of time.
- Hospital stays are minimized due to Remote Patient Monitoring.
- Hospital visits for normal routine check-ups are minimized.
- Patient health parameter data is stored over the cloud. So it is more beneficial than maintaining the records on printed papers kept in the files.
- In this work, a system for 24x7 human health monitoring is designed and implemented.
- Low cost, Good Performance.



Article Title: Advanced IoT Based Combined Remote E-Health Monitoring and Home Testing Using Arduino Uno

9. Conclusion and Future Scope

9.1 Conclusion

We face a higher danger of health issues these days. In general, smart sensors attached to the human body are connected to an Internet of Things (IoT)-based health care platform for daily health checks. We talked about Internet of Things-based patient health monitoring systems in this study. The significance of medical patient observation, ongoing remote monitoring is required. Through the use of the web and live monitor services, our project work provides the option to continuously watch patients. This device uses heartbeat, blood pressure, and temperature sensors to monitor a person's heart rate, blood pressure, and humidity—even when they're at home. This technology also supports the hospital monitoring system, which has a single person in the server room keeping an eye on every patient.

9.2 Future Scope

Our suggested system uses a Wi-Fi module to allow us to monitor the patient in a different way as well as the entire ward or patient room from a distance. As a result, a feature for person falls will be included, which will help senior citizens. But we'll upgrade the software and hardware components in the future. We will update both the website and the apps under the software section. We want to incorporate an intuitive function into the website that will automatically display the patient's name, date, and time in the ECG segment

References

1. Mohammad Monirujjaman Khan, Turki M. Alanazi, Amani Abdulrahman Albraikan, and Faris A. Almallki "Iot Based Health Monitoring System Development and Analysis" VOLUME-2022 ISSUE 21 April 2022.
2. Dr. B. Srikanth, P. Divya, P. Nandini, Sk. Sabira and T. Bharathi "Patient Health Monitoring using Arduino" IJRD VOLUME 05 ISSUE 05 2020.
3. Pandimadevi Ganesan, Thusara Hameed, Maheswari Maruthakutti and Selvakumar Vairamuthu "Design of IOT Based Health Monitoring System" SJEAT VOLUME 19 ISUUE 23 2022.
4. Priyanka Chavan, Chaitali Rasal, Shashikant Shirgire and Prof. Kalpita Mane "IOT Based Patient Health Monitoring System Using Arduino" IJIRT Volume 08 Issue 2021.
5. Richa, Anwasha Das, Ajeet Kumar Kushwaha and Prof. Mini Sreejith "An IoT based Health Monitoring System using Arduino Uno" IJERT Vol 10 Issue 03 March 2021.
6. Dr.M. MohanKumar, Kirthana, Pavithra Banu and Poo MahaVinu Shree J.B, Madhumitha "Multi-Parameter Smart Health Monitoring System Using Arduino-Uno" IRJMETS Vol 03 Issue 03 March 2021.



Article Title: Advanced IoT Based Combined Remote E-Health Monitoring and Home Testing Using Arduino Uno

7. P. Jebane, P. Anusuya, M. Suganya, S. Meena and M. Diana Amutha Priya “IoT Based Health Monitoring and Analysing System Using Thing speak Cloud & Arduino” IJTRET Vol 05 Issue 04 Aug 2021.
8. Roshni Rajesh Nair, Nazla M, Shamrin T K, Prasoon Raj K K and AshithaT “Real Time Patient Monitoring System Based on Internet of Things” IJCRT Vol 09 Issue Oct 2021.
9. Ebrahim Al Alkeem¹, Dina Shehada¹, Chan Yeob Yeun¹, M. Jamal Zemerly, Jiankun Hu “New secure healthcare system using cloud of things”, Springer Science+Business Media New York 2017.
10. Afef Mdhaffar, Tarak Chaari, Kaouthar Larbi, Mohamed Jmaiel and Bernd Freisleben “IoT-based Health Monitoring via LoRaWAN”, IEEE EUROCON 2017.