



Article Title: IoT Based Smart Energy Meter for Tariff Calculations

IoT Based Smart Energy Meter for Tariff Calculations

M. T. Abisheak^{1,*}, S. Aravind Babu², P. Godwin³, M. Mohamed Fahmi⁴, S. Nithya⁵

^{1, 2, 3, 4}Student, Department of Electrical and Electronics Engineering, Rohini College of Engineering and Technology.

⁵Assistant Professor, Department of Electrical and Electronics Engineering, Rohini College of Engineering and Technology.

ABSTRACT

The commonplace items that are all around us will operate as proactive Internet users in the future Internet of Things (IoT), producing and consuming data. The Internet of Things is made up of more than only the gadgets that are already widely used in the technology industry (like automobiles or refrigerators), as well as items that are not native to this area (like clothing or perishable food), or even living things (like farms, forests, or cattle). Healthcare, logistics, domestics, entertainment, and other industries will all be able to see a qualitative and quantitative leap in the integration of computing capabilities into a wide range of objects and living things. Numerous innovations in the field of electricity departments have been brought about by the significant shifts in technology over the past ten years. It is possible to pay the electricity bill. You can pay the electricity bill right now with E-Seva centers, online banking, and even via mobile devices. Units consumed in that meter represent the user's electricity consumption in this project accessible on a computer or mobile device over the internet via an IoT module, and a 16x2 LCD is included for reading units. The values are shown on the LCD whenever the count value or the meter's units are altered. This system uses an 18V supply for the load and a 5V regulated power supply for the microcontroller unit. This is supplied by the 2 amps, 18 volt transformer. The regulated 5V power used for the recharging unit is supplied by a different 18V, 750mA transformer. Therefore, this project offers the greatest way for consumers to know how much power they use on a daily basis and that they also have control over that quantity of electricity.

Keywords: Internet of Things (IoT), LCD, GSM, Electricity.

1 Introduction

In contemporary energy distribution systems, the accurate monitoring of electricity usage is paramount for ensuring efficient billing, resource management, and customer satisfaction. However, existing systems often fall short in providing real-time insights into electricity consumption, leading to issues such as inaccurate billing, inconsistent power supply, and customer dissatisfaction. To address these challenges, this paper proposes a novel approach leveraging Internet of Things (IoT) technology to enable real-time monitoring of electricity usage by consumers. The system is designed to provide distribution companies with timely and



Article Title: IoT Based Smart Energy Meter for Tariff Calculations

accurate data on electricity consumption, which can be accessed via mobile phones, PCs, and displayed on LCD screens. By implementing this system, distribution companies can overcome the limitations of traditional billing methods and enhance their ability to track maximum demand, detect threshold values, and ensure proper billing practices. Moreover, providing customers with access to their electricity usage data empowers them to make informed decisions about their energy consumption, ultimately leading to a more efficient and transparent energy ecosystem. This project presents the design, implementation, and evaluation of the proposed real-time electricity usage monitoring system, highlighting its benefits in terms of improved billing accuracy, enhanced customer experience, and efficient load management. Additionally, considerations such as data security, scalability, compatibility, user interface design, and maintenance are discussed to ensure the practical viability and effectiveness of the proposed system. Through this research, we aim to contribute to the advancement of energy billing and management systems, paving the way for a more sustainable and technologically advanced energy infrastructure.

2 Literature Survey

For this work, we explored the existing methodologies employed in energy metering and billing systems, shedding light on their limitations and areas for improvement. Previous systems predominantly relied on GSM technology for transmitting notifications to users, often lacking advanced features for providing real-time feedback on energy consumption patterns and opportunities for efficiency enhancements. This deficiency in real-time feedback mechanisms hampers consumers' ability to actively manage their energy usage and make informed decisions to optimize efficiency. Furthermore, traditional energy metering systems typically involve manual intervention, such as in the case of unpaid bills where electricity board workers physically visit homes to disconnect power. Such manual processes not only entail logistical challenges but also incur additional costs and inconvenience for both consumers and service providers. Moreover, the existing billing systems employed by distribution companies struggle to effectively monitor and adapt to the changing maximum demand of consumers. This inability to dynamically track demand fluctuations poses challenges in resource allocation and load management, leading to inefficiencies in energy distribution and utilization. To address these limitations, this study proposes a novel approach wherein energy metering and billing systems are integrated with mobile server technology. This integration enables remote control and management of electricity distribution, providing distribution companies with real-time insights into energy consumption patterns and demand fluctuations. By leveraging mobile server technology, the proposed system aims to enhance the efficiency, accuracy, and responsiveness of energy metering and billing processes, ultimately facilitating better resource management and improved service delivery.



3 Existing System

The distribution companies are unable to monitor the fluctuating maximum demand of customers under the current billing system. The customer is having issues with things like receiving past-due bills for amounts that have already been paid, as well as inconsistent power supply and quality even in cases where payments are made on a regular basis. Monitoring customer load promptly is the solution to all of these issues. This will ensure proper billing, allow for the tracking of maximum demand, and enable the detection of threshold values. All of these factors need to be considered when creating an effective energy billing system.

4 Block Diagram

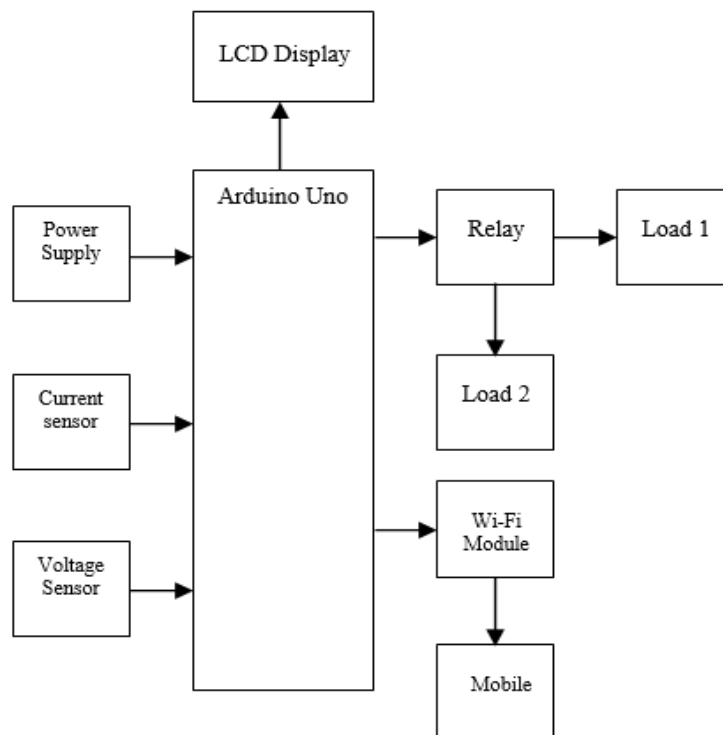

5 Proposed System

The project involves monitoring electricity usage by users via an IoT module, making this information accessible on mobile phones/PCs through the internet, and displaying it on a 16x2 LCD screen. Whenever there's a change in electricity usage (measured in units), these alterations are reflected both on the mobile/PC interface and on the LCD screen. In proposed system we use gsm with IoT system. This system can use monitor energy meter 24*7 through online and control the whole system through mobile app. When the calculated unit over 80 the this system send alert to the and when the calculated unit over 100 the this system send notification to the user.



6 Circuit Diagram

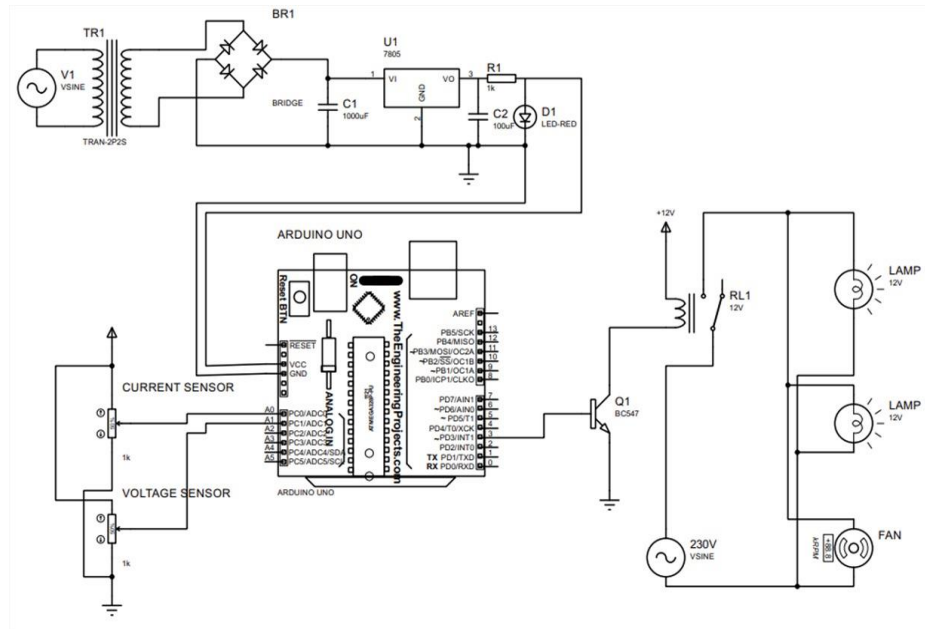

7 Hardware Specifications

7.1 Energy Meter

An electricity meter, electric meter, electrical meter, energy meter, or kilowatt-hour meter is a device that measures the amount of electric energy consumed by a residence, a business, or an electrically powered device. Electric meter or energy meter measures the total power consumed over a time interval.



Figure 1: Energy Meter

Electric Utilities use electric meters installed at customers' premises for billing and monitoring purposes. They are typically calibrated in billing units, the most common one being the kilowatt hour (*kWh*). They are usually read once each billing period.



Article Title: IoT Based Smart Energy Meter for Tariff Calculations

7.2 Current Sensor

A current sensor detects and measures the electric current passing through a conductor. It turns the current into a quantifiable output, such as a voltage, current, or digital signal, which may be utilised in a variety of applications for monitoring, control, or protection.

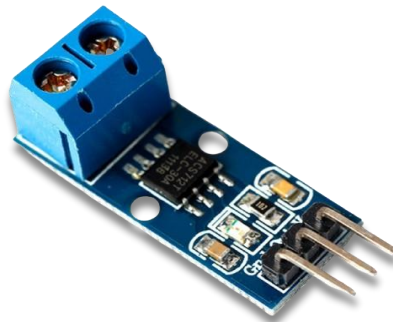

Figure 2: *Current Sensor*

7.3 Voltage Sensor

A voltage sensor is a device that measures the voltage of an electrical circuit. Voltage sensors are used in many applications, including monitoring and controlling equipment and machinery.

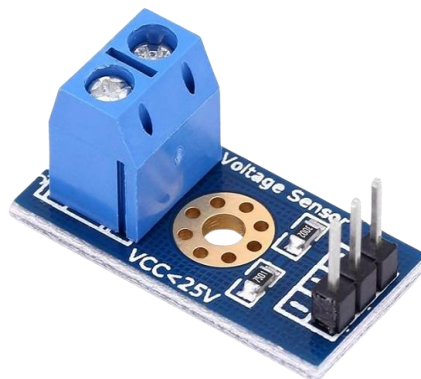

Figure 3: *Voltage Sensor*

7.4 Wi-Fi Module

Wifi modules or wifi microcontrollers are used to send and receive data over Wi-Fi. They can also accept commands over the Wi-Fi. Wi-Fi modules are used for communications between devices. They are most commonly used in the field of Internet of Things.



Article Title: **IoT Based Smart Energy Meter for Tariff Calculations**



Figure 4: *Wi-Fi Module*

7.5 LCD Display

LCD (Liquid Crystal Display) is a type of flat panel display which uses liquid crystals in its primary form of operation. LEDs have a large and varying set of use cases for consumers and businesses, as they can be commonly found in smartphones, televisions, computer monitors and instrument panels.



Figure 5: *LCD Display*

7.6 Relay

Relays are electrically operated switches that open and close the circuits by receiving electrical signals from outside sources. Relay technology can be divided into two main categories: Movable contacts (mechanical relay) and no movable contact.



Figure 6: *Relay*



Article Title: IoT Based Smart Energy Meter for Tariff Calculations

8 Result

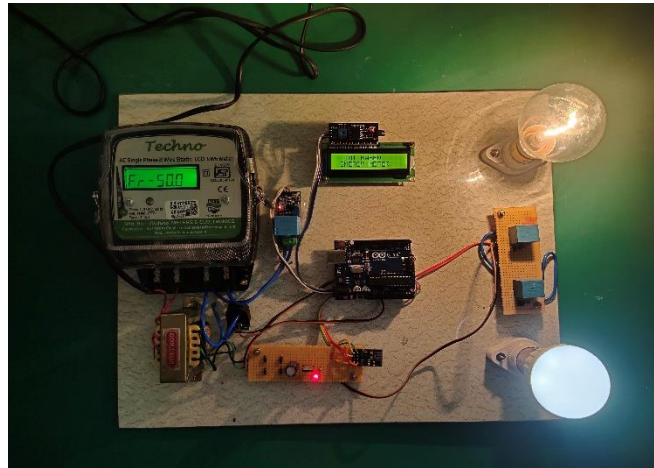

Figure 7: Proposed prototype of IoT based Energy Meter

The above figure is the prototype implementation of this project, which can be utilized in a real time system.

9 Conclusion

The main cause for the design of IoT based E-meter is to reduce the power consumption in house. It avoids the human intervention reduces the cost, save human power. It works both automatically and manually. This meter sends billing directly to mobile daily and as before due date without causing human intervention his computerization for diminish the work costs as well as makes the framework more effective and exact.

Acknowledgment

We take this opportunity to express our hearty thanks to all those who helped us in the completion of the paper. We express our deep sense of gratitude to our guide Mrs. S. Nithya, Assistant Professor, EEE Department, Rohini College of Engineering & Technology for her guidance and continuous motivation. We gratefully acknowledge the help provided by her on many occasions, for improvement of this project report with great interest. Lastly we would like to thank all the staff members, colleagues, and all our friends for their help and support from time to time.

References

1. Nikhil V. Patil; Rohan S. Kanase; Dnyaneshwar R. Bondar; P. D. Bamane, Year: 2017, "Intelligent Energy Meter with Advanced Billing System and Electricity Theft Detection", International Conference on Data Management, Analytics and Innovation (ICDMAI) Zeal Education Society, Pune, India.



Article Title: IoT Based Smart Energy Meter for Tariff Calculations

2. Mohammad G. Mortuza; Zia U. Ahmed; Hassan Jaki; Md. Razu Ahmed; Mohammed J. Uddin; Md. Humayun Kabir, Year: 2020, "GSM Based Automatic Energy Meter Reading and Billing System", European Journal of Engineering Research and Science.
3. Md. Abrarul Alam; Mohammad Zeyad, Year: 2019, "Smart Cities and Buildings: GSM Based Smart Electric Energy Meter Billing System", IEEE International Conference on Power, Electrical, and Electronics and Industrial Applications.
4. Diogo Koenig; Marilda S. Chiamonte; Alexandre Balbinot, Year: 2008, "Wireless Network for Measurement of Whole-Body Vibration", Sensors, Vol: 8, pp. 3067 – 81.
5. Minal S. Khandare; Anjali Mahajan, Year: 2007, "Mobile Monitoring System for Smart Home", ICETET, 2010, 3rd International Conference on Emerging Trends in Engineering and Technology, pp. 848 – 852.
6. J. Lee, Y. Su, C. Shen, "A Comparative Study of Wireless Protocols", pp. 46 – 51.
7. Paolo Barsocchi; Erina Ferro; Filippo Palumbo; Francesco Potorti, Year: 2014, "Smart meter led probe for real time appliance load monitoring", IEEE 2014 SENSORS, pp. 1451 – 1454.
8. Md. Masudur Rahman; Noor-E-Jannat; Mohd. Ohidul Islam; Md.Serazus Salakin, Year: 2015, "Arduino and GSM Based Smart Energy Meter for Advanced Metering and Billing System", 2nd International Conference on Electrical Engineering and Information & Communication Technology (ICEEICT).
9. Nattachart Tamkittikhun; Thitinan Tantidham; Puwadech Intakot, Year: 2015, "AC Power Meter Design Based on Arduino: Multichannel Single- Phase Approach", International Computer Science and Engineering Conference (ICSEC).
10. Claudio De Capua; Gianluca Lipari; Mariacarla Lugarà; Rosario Morello, Year: "A Smart energy Meter for Power Grids", I2MTC, 2014, 2014 IEEE International Instrumentation and Measurement Technology Conference, pp. 878 – 883.
11. M. R. M. S. B. Rathnayaka; I. D. S. Jayasinghe; Enit Jayanth; S. I. Swarnajith; M. A. S. C. Manamendra; G. Wimalaratne, Year: 2013, Mobile Based Electricity Billing System (MoBEBIS)", International Journal of Scientific and Research Publications, Vol: 3, no: 4, pp. 2250 – 3153.
12. Elise Andrey; Jordan Morelli, Year: 2010, "Design of a smart meter techno-economic model for electric utilities in Ontario", Electric Power and Energy Conference (EPEC), pp. 1 – 7.
13. D. Egan, Year: 2005, "The Emergence of ZigBee in building automation and industrial controls", IEE Computing & Control Engineering, Vol: 16 no: 2, pp. 14 – 19.



Article Title: IoT Based Smart Energy Meter for Tariff Calculations

14. John Newbury; William Miller, Year: 2001, "Multiprotocol Routing for Automatic Remote Meter Reading Using Power Line Carrier Systems", IEEE Power Delivery, Vol: 16 no: 14, pp. 1 – 4.
15. H. K. Chan, Year: 2010, "Agent-Based Factory Level Wireless Local Positioning System with ZigBee Technology", IEEE Systems Journal, Vol: 4 no: 2, pp. 179 – 85.
16. Cheng Qiang; Sun Ji-Ping; Zhang Zhe; Zhang Fan, Year: 2009, "ZigBee Based Intelligent Helmet for Coal Miners", IEEE World Congress on Computer Science and Information Engineering, pp. 433 – 35.
17. Masood Khan; Pratik Bhosle; Sandesh Dalvi, Year: 2015, "Wireless Electronic Notice Board Using GSM Technology", International Journal for Research in Applied Science & Engineering Technology, Vol: 3, Issue-V.
18. H. G. Rodney; I. E. E. E Tan; C. H. Lee; V. H. Mok, Year: 2007, "Automatic Power Meter Reading system using GSM Network", The 8th International power Engineering Conference, pp: 465 – 469.
19. T. El-Djazairy; B. J. Beggs; I. F. Stewart, "Investigation of the use of the Global System for Mobile Communications (GSM) network for metering and load management telemetry", Electricity Distribution, Part 1: Contributions, CIRED, 14th International Conference and Exhibition on (IEE Conf. Publ. No. 438).
20. T. Maity; S. Das; B. Datta, Year: 2009, "A PC based Intelligent Wireless Energy Metering and Online Billing Solution for Domestic Consumers", The Institution of Engineers (India) Journal (ET), Vol: 89, pp. 8 – 12.
21. Liting Cao; Jingwen Tian; Dahang Zhang, Year: 2006, "Networked Remote Meter-Reading System Based on Wireless Communication Technology", Proceedings IEEE International Conference on Information Acquisition, China, pp. 172 – 176.
22. Himshekhar Das; L. C. Saikia, Year: 2015, "GSM Enabled Smart Energy Meter and Automation of Home Appliances", IEEE.
23. H. G. Rodney Tan; C. H. Lee; V. H. Mok, Year: 2007, "Automatic Power Meter Reading system using GSM Network", The 8th International Power Engineering Conference.
24. P. Loganthurai; M. Shalini; A. Vanmathi; M. Veeralakshmi; V. Vivitha, Year: 2017, "Smart energy meter billing using GSM with warning system", in 2017 IEEE International Conference on Intelligent Techniques in Control, Optimization and Signal Processing (INCOS) pp. 1 – 4, IEEE.
25. Sarwar Shahidi; Md Abdul Gaffar; Khosru M. Salim, Year: 2013, "Design and implementation of digital energy meter with data sending capability using GSM network", in 2013 2nd International Conference on Advances in Electrical Engineering (ICAEE) pp. 203 – 206, IEEE.



Article Title: IoT Based Smart Energy Meter for Tariff Calculations

26. Subhashis Maitra, Year: 2008, “Embedded Energy Meter- A new concept to measure the energy consumed by consumer and to pay the bill”, Power System Technology and IEEE Power India Conference.
27. J. Holmes; D. Campbell, “Communicating with domestic electricity meters”, Schlumberger Industries UK, pp.129 – 133.
28. Li Kaicheng; Liu Jianfeng; Yue, Congyuan; Zhang Ming, Year: 2008, “Remote power management and meter-reading system based on ARM microprocessor”, Precision Electromagnetic Measurements Digest, CPEM 2008, Conference on Digital Object Identifier.