



## Smart Gardening Based On Automatic Sprinkler System Using Multi-Sensors

H. Naveen Samraj<sup>1</sup>, J. Simiyon<sup>1</sup>, P. Selva Bharath<sup>1</sup>, K.M. Annammal<sup>2</sup>

<sup>1</sup>First Year Student, Department of Computer Science and Engineering, Grace College of Engineering, Thoothukudi, TamilNadu, India

<sup>2</sup>Assistant Professor, Department of Computer Science and Engineering, Grace College of Engineering, Thoothukudi, TamilNadu, India

950322104065@gracecoe.org<sup>1</sup>, 950322104088@gracecoe.org<sup>1</sup>,

950322104185@gracecoe.org<sup>[1]</sup>, annammal@gracecoe.org<sup>[2]</sup>

### ABSTRACT

The external need of every person in this world is oxygen. Plants play a vital role in maintaining the carbon dioxide and oxygen content of the air. A lot of plants are destroyed every day due to the urbanization process. The number of plantings made will also decrease. In addition to these things, more plants die due to a lack of maintenance. Smart gardening represents the application of modern information and communication technologies to planting. It automatically checks the soil moisture under the tree and plants in the garden and if the moisture is low, it displays a message and automatically pours water to the plants from the water tank to which it is connected. Precise application of the irrigation method is required as there may be a lack of rainfall or there may be dry areas. For this reason, an automated irrigation system is used, which is suitable for all climatic conditions. The soil moisture sensor will sense the water content and indicate whether to pump water or not. This will help reduce water wastage and also help plant growth even when one is not physically present. Internet of Things (IoT) enables various plant monitoring and selection applications, automatic irrigation decision support, etc. sensor data related to soil moisture and temperature captured and accordingly KNN (K-Nearest Neighbor) classification machine learning algorithm deployed to analyze sensor data for prediction to irrigate the soil with water. It is a fully automated system where devices communicate with each other and use intelligence during irrigation. The main goal of this project is to preserve the nature of plants by constantly monitoring the parameters leading to an increase in the life of plants and humans.

**Keywords:** IOT, smart, garden, irrigation, KNN.

### 1 Introduction

Automation rules today's world. It is a technique of using computers or mobile phones in monitoring and control simple parameters of everyday life. The standard of our life will be nourished by the practice of using automation for simple things. Using the IoT concept, we produce sensors for mutual communication that are powerful in automation. An important aspect of this prototype is to save costs and ensure safety. When people try when plant and establish their garden, they were careful with maintenance only in the initial stages. As days continue due to lack of maintenance, the plants will be destroyed. The Internet of Things can



offer a feasible solution to this. The garden can be modernized with electronic technology that continuously monitors the condition of the plants and soil to provide watering and shade to the plants as needed. All of this can be controlled and monitored online with an IoT application. In this project, sensors measure soil moisture and temperature and automatically control water flow into the garden. People often grow unsuitable plants in their gardens, so they usually die from lack of water or even too much sunlight. In this project, we are using sensors to get parameter and process values he uses a microcontroller to control the survival of plants in the garden. Based on soil type and plant type the water requirement for the plant is defined. The user is also regularly informed about the condition of the plants.

### **1.1 Internet of Things (IoT)**

The Internet of Things (IoT) is an ecosystem of connected physical objects that are accessible via the Internet. It is a system of interrelated computing devices, mechanical and digital machines, objects, or people that are provided unique identifiers and the ability to transfer data over a network without the need for human-to-human or human-to-computer connections interaction. It includes traditional computing devices such as laptops, tablets, and smartphones, but also it includes a growing list of other devices that have recently made the Internet possible. This includes, for example, household appliances, automobiles, wearable electronics, security cameras, and many other things. For the device to be part of The Internet of Things must be able to communicate with other devices. Therefore, it requires some type of built-in cable connection or wireless communication. Most IoT devices support Wi-Fi, but Bluetooth can also be used to transfer data facilities in the vicinity. IoT devices are commonly called "smart devices" because they can communicate with others things. In addition to being able to communicate, many IoT devices also contain a variety of useful sensor information. Although the Internet of Things is still in its infancy, it provides promising opportunities for the future. In Over time, the Internet of Things will become less of an abstract idea and more of a way of life.

### **1.2 Smart Home**

Smart Home has become a revolutionary ladder of success in living spaces and is predicted as Smart homes will be as common as smartphones. With IoT, we could turn on the air conditioner before coming home or switch turn off the lights even after you leave home, or you can unlock the door for friends for temporary access even when you're not home. Smart Home products promise to save time, energy, and money.

## **2 KNN Algorithm**

The k-Nearest Neighbor algorithm is one of the simplest machine learning algorithms based on the supervised learning technique.

The K-NN algorithm assumes similarity between the new case/data and the available cases and assigns the new case to the category most similar to the available categories.

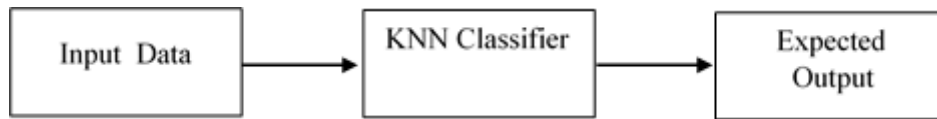

**Figure 1:** *Flow of KNN algorithm*

### The KNN algorithm works

- Select the number of K neighbors
- Calculate the Euclidean distance to the number of neighbors
- Take the K nearest neighbors according to the calculated Euclidean distance.
- Between these k neighbors, count the number of data points in each category.
- Assign new data points to the category for which the number of neighbors is maximum.
- Our model is ready.

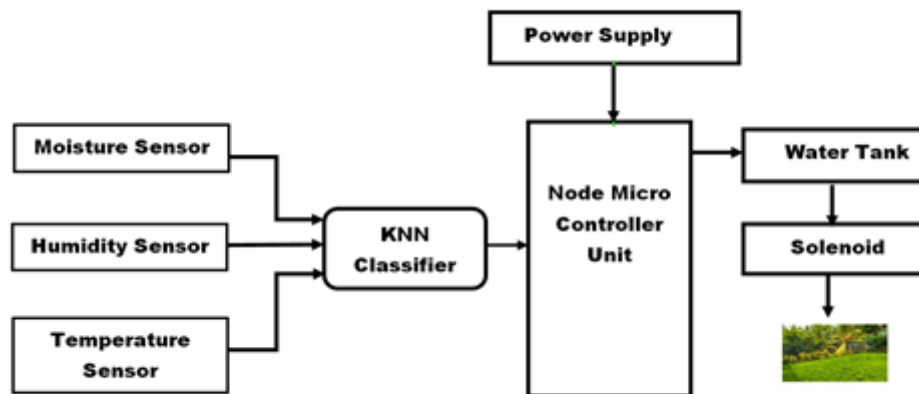

**Figure 2:** *IoT Based Automated Irrigation System*

### 3 Automated Irrigation Process

The irrigation process provides irrigation water at the highest possible rate by using artificial intelligence to design a smart irrigation system that controls the irrigation mechanism with the necessary tools for sensing soil moisture and temperature, providing alerts for any change in parameters entered as baseline values for comparison and installation of system sensors using the KNN algorithm.

Our method constructs a KNN model for the data, which replaces the data and serves as the basis of classification. The value of k is determined automatically, changes for different data, and is optimal in terms of classification accuracy.

The sensors work to measure the humidity and temperature in the soil every day it prevents the automatic watering process at high humidity and is enabled when the humidity is low. The model of the intelligent automatic irrigation system was created using the K-nearest algorithm, which is one of the machine learning algorithms. It is used to investigate and predict irrigation.



### 3.1 Sensors

We live in a world of sensors. In our homes, offices, cars, etc., you can find different types of sensors that make our lives easier by turning on the lights by detecting our presence, adjusting the room temperature, detecting smoke or fire, making us delicious coffee, opening the garage door once our car is at the door and many other tasks.

All these and many other automation tasks are possible thanks to sensors. Before we get into the details of what a sensor is, what the different types of sensors are, and the applications of these different types of sensors, let's first look at a simple example of an automated system made possible by sensors (and many other components).

### 3.2 The Proposed System Requirements

This project was implemented with the motive of preserving the nature of plants through constant monitoring parameters leading to an increase in the lifespan of plants. The project deals with automated temperature and humidity controls and all sensors used are commercially available. Various sensors are used to maintain nature plants.

## 4 Conclusion

It has been verified that an IoT-based smart garden implementation works satisfactorily by connecting various soil parameters to the cloud and was successfully controlled remotely via mobile app and web page. The proposed system not only monitors sensor data such as humidity, humidity, temperature, and ultrasound but also controls other parameters as required. The initial cost and installation of this system are cheap, so it can be implemented anywhere. With the development of sensor technology, the system can be upgraded to the next level, which helps users to use their investment in an economical way. If soil nutrient sensors can be installed, then the system can be adjusted to deliver fertilizer precisely to the garden. This system saves manpower and makes efficient use of available water resources, ultimately resulting in higher profits.

## References

1. T. Thamaraimanalan; S.P. Vivekk; G. Satheeshkumar; P. Saravanan, Year: 2018, "Smart Garden Monitoring System Using IOT", Asian Journal of Applied Science and Technology.
2. M. Newlin Rajkumar; S. Abinaya; V. Venkatesa Kumar, Year: 2017, "Intelligent irrigation system — An IOT based approach," 2017 International Conference on Innovations in Green Energy and Healthcare Technologies (IGEHT).
3. Anas H. Blasi; Mohammad A. Abbadi; Rufaydah Al-Huweimel, Year: 2020, "Machine Learning approach for Automatic Irrigation System in Southern Jordan Valley," Engineering Technology and applied science research.
4. Safwan A. Hamoodi; Ali N. Hamoodi; Ghanim M. Haydar, Year: 2020, "Automated irrigation system based on soil moisture using arduino board", Bulletin of Electrical Engineering and Informatics, Vol: 9, no: 3, pp. 870-876.



**Article Title: Smart Gardening based on automatic sprinkler system using multi-sensors**

5. Aashika Premkumar; K. Thenmozhi; Padmapriya Praveenkumar; P Monishaa; Rengarajan Amirtharajan, Year: 2018, "IOT Assisted Automatic Irrigation System using wireless sensor nodes, 2018 International Conference on Computer Communication and Informatics (ICCCI).
6. Gagandeep; Dinesh Arora; Hardeep Singh Saini, Year: 2017, "Design and implementation of an automatic irrigation feedback control system based on monitoring of soil moisture. 2017 International Conference on Inventive Computing and Informatics (ICICI).
7. S. Akshay; T.K. Ramesh, Year: 2020, "Efficient Machine Learning Algorithm for Smart Irrigation", 2020 International Conference on Communication and Signal Processing (ICCSP), pp. 28-30.
8. Anusha R; Polepally Vamshi Krishna; Harsh Jain; Dosada Suresh, Year: 2020, "Analysis of Soil Moisture Data using IOT & KNN Algorithm" Journal of Engineering Science, Vol: 11, no: 11.
9. M. Benedict Tephila; R. Aarthi Sri; R. Abinaya; J. Aiswarya Lakshmi; V. Divya, Year: 2022, "Automated Smart Irrigation System using IoT with Sensor Parameter" 2022 International Conference on Electronics and Renewable Systems (ICEARS).
10. M. Monica; B. Yeshika; G.S Abhishek; H.A Sanjay; Sankar Dasiga, Year: 2017, "IoT based control and automation of smart irrigation system: An automated irrigation system using sensors, GSM, Bluetooth and cloud technology" 2017 International Conference on Recent Innovations in Signal processing and Embedded Systems (RISE).
11. Kiranmai Pernapati, Year: 2018, "IoT Based Low Cost Smart Irrigation System" 2018 Second International Conference on Inventive Communication and Computational Technologies (ICICCT).
12. Rodrigo Togneri; Carlos Kamienski; Ramide Dantas; Ronaldo Prati , Attilio Toscano; Juha-Pekka Soininen; Tullio Salmon Cinotti, "Advancing IoT-Based Smart Irrigation," IEEE Internet of Things Magazine.
13. Mohammad Taz Uddin; Tanvir Ahmed Chowdhury; Rashedur M. Rahman, Year: 2021, "Design and Implementation of Automatic Smart Irrigation System," 2021 IEEE 12th Annual Ubiquitous Computing, Electronics & Mobile Communication Conference (UEMCON).
14. Harsh Mahajan; Megha Manglani; Georgina Frank; Amish Mashru, Year: 2022, "IoT Based Smart Agriculture with Automatic Irrigation System," Vol: 8, no: 3, pp. 2395-4396.
15. P K Devan; K Arun; N H Arvindkumar; R Aravind; R. Dinesh Kumar, Year: 2021, "IoT based solar powered smart irrigation system journal of Physics: Conference Series," Vol: 2054, International Conference on Advances in Thermal Engineering and Applications.